

# LPT-FCLEAVA05

## Fiber Optic High Precision Cleaver User Manual

LPTFCLEAVA05\_UM\_ENB01W



# LPT-FCLEAVA05

## Fiber Optic High Precision Cleaver

### User Manual

#### **A** Safety instruction:

- Do not touch the blade with hand, in order not to damage the blade or harm yourself.
- The fiber and fragment of the fiber is sharp, clear them away as possible.
- Please properly place the fiber fragment, a special collector is recommended.
- If there is abnormal, please stop using cleaver and contact LanPro Networks.  
Do not disassemble or refit by yourself without proper instruction.

**Product Description**

<b>Applicable diameter of the bare fiber</b>	125um
<b>Applicable number of the fiber core</b>	Single core (0.25mm & 0.9mm). 12 cores ribbon fiber
<b>Cutting length of the fiber</b>	10mm
<b>Size</b>	100 (W) x 80 (D) x 62 (H) mm
<b>Weigth</b>	About 379g

**Optical accessories**

<b>Blade</b>	LPT-CC10
--------------	----------

**B Fiber Cleaver operating instruction**

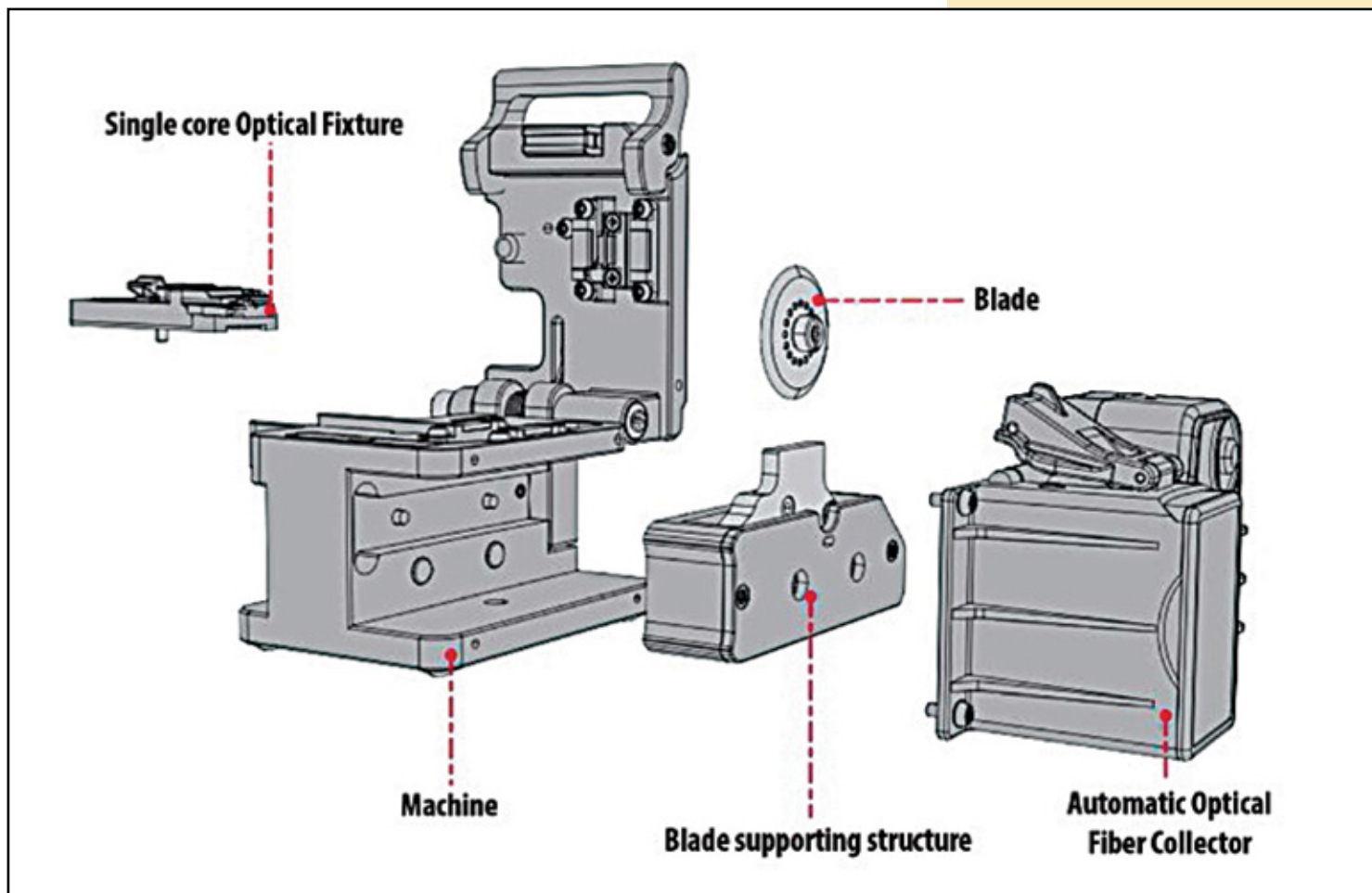

**OPERATING METHOD**

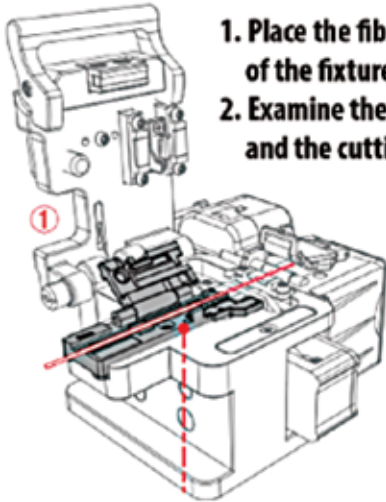

1. Place the fiber into the groove of the fixture
2. Examine the location of the fiber and the cutting length

**Single Core Optical Fiber Fixture**

For example, if the cutting length is 16mm, align the coating edge and the 16mm scale mark of the fixture, and keep the bare optical fiber in the groove

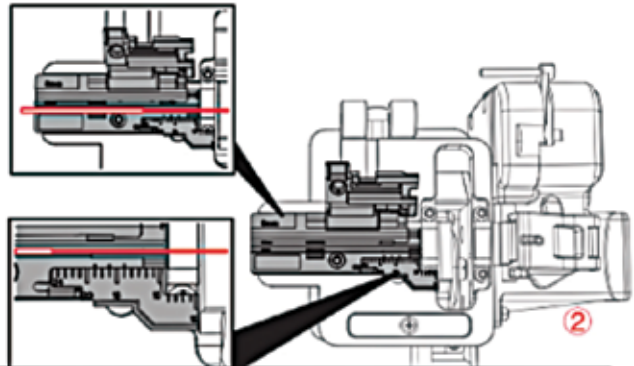

**Installation and disassemble of the collector**

Align 1 to 4 and insert the collector into the machine and spin tight the screw at 2, 3 and 4 in order to fix the collector onto the cleaver

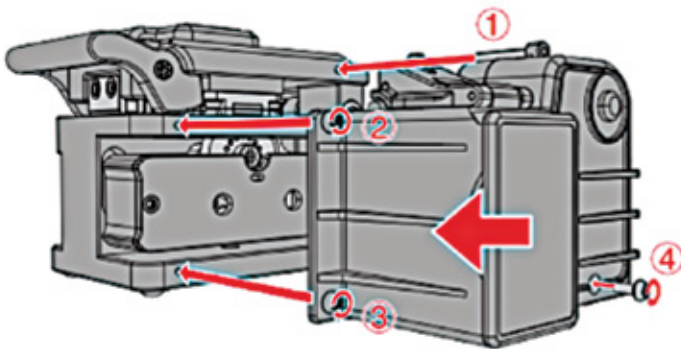

Spin loose the screws at 2, 3, 4, take off the collector.

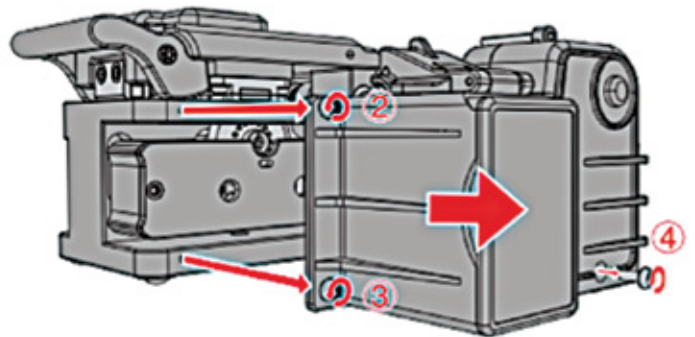

After the examination close the fixture cover, close the upper cover of the cleaver, manually cut off the fiber, and the left fibers will automatically fall into the collector.

**Manually Cutting, Automatically Returning!**

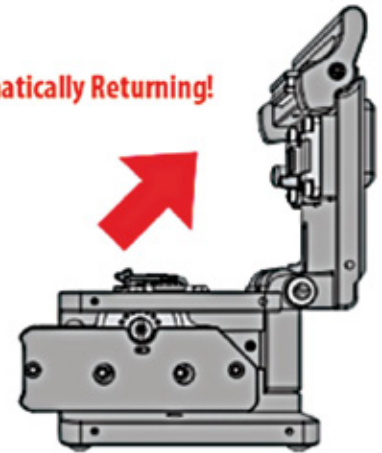
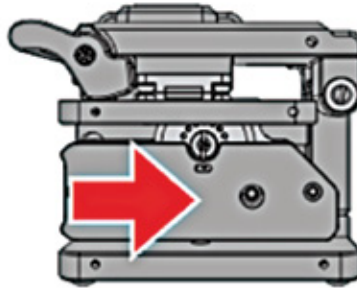
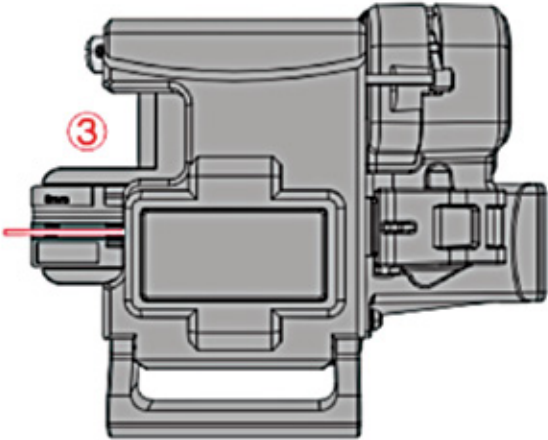

**EXAMPLE OF THE CUTTING LENGTH:**

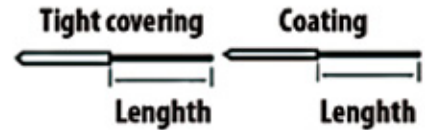

**ADJUSTMENT THE BLADE**

1. Use T8 screw wrench to spin loose the screw at the place 1, insert into place 2 with tool and spin anticlockwise to the next scale mark, and the spin tight the screw at the place 1.

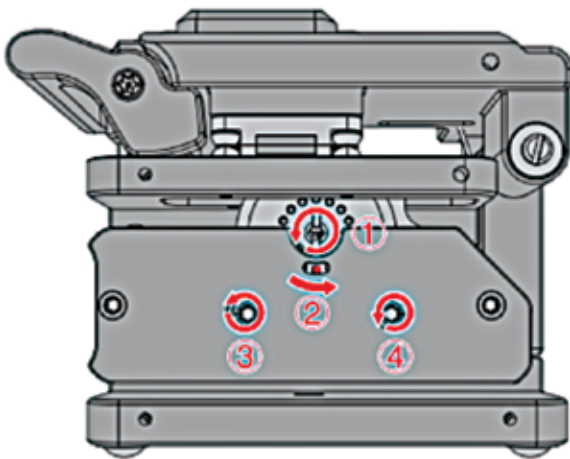
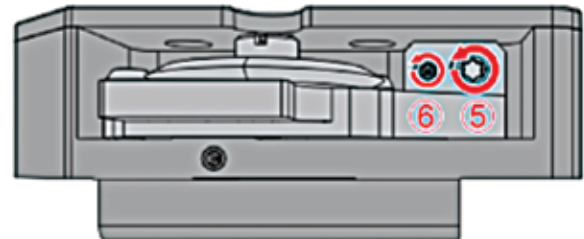

2. Use T8 wrench to spin the loose the screw at 3 and 4.
3. Spin M3 on the left to adjus the fixing screw 6 to change the height of the blade. Spin the screw clockwise to the raise the blade, spin the screw anticlockwise to lower the blade.
4. After adjustment, spin tight the fixing screws 3 and 4 successively, at the same time spin tight M3 to adjust T8 box spanner 5 beside the fixing screw.

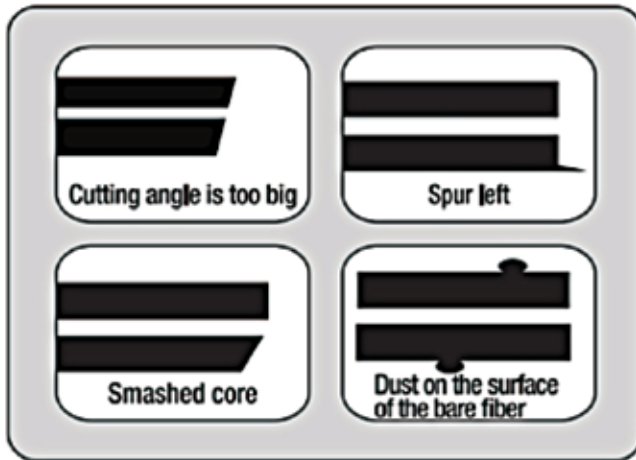
**DAILY CLEANING**

1. The fiber is not well placed
  - Please vertically place the fiber
2. The blade is place to high
  - Please adjust the height of the blade
3. There is dust or other objects on the rubber cushion or the fixture.
  - Please clean the rubber cushion or the fixture
4. There is dust or other objects on the fiber
  - Please strip the coating of the fiber again, and the clean the fiber with alcohol

**IF THE BAD CUTTING REPEATEDLY OCCUR,  
PLEASE CONTACT THE MAINTENANCE DEPARTMENT OF OUR COMPANY.**

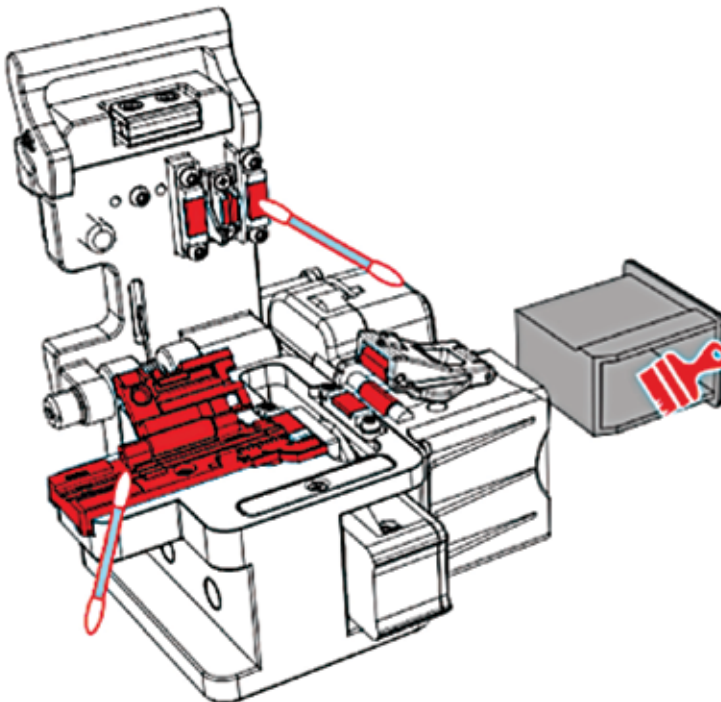
**DAILY CLEANING**

To maintain the cutting function of the fiber cleaver, please clean it as soon as possible after use.

Use dehydrated alcohol and cotton swap to clean the places according to the map.

The grooves of thje fiber fixture also need to be cleaned.