

LPT-Xfast 4-Pair Termination Tool for X-Class Jacks made by LanPro, 123 Manual

LPTXfast_M123_ENB01W



LPT-Xfast 4-Pair Termination Tool for X-Class Jacks made by LanPro, 123 Manual

The **LPT-Xfast** 4-Pair Termination Tool has been designed for the termination of all the LanPro **X-Class** Series Keystone compatible Jacks.

This M123 document will guide you on its use for the preparation of quality terminations.

A Components of the LPT-Xfast tool

It is composed of two parts, the head including the die and the body.

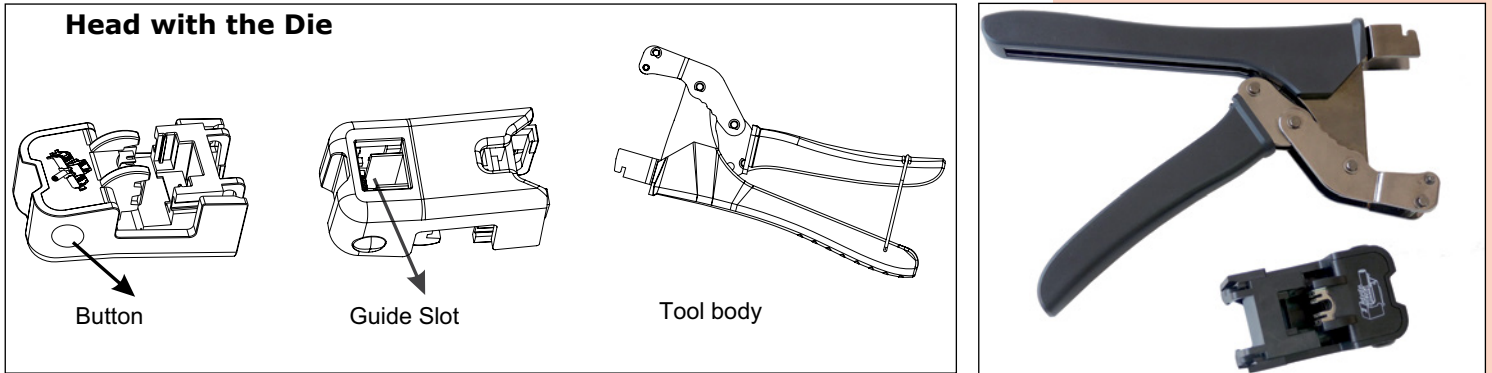

B How to assemble the LPT-Xfast tool before use

1.- Insert the guide slot of the head with the Die into the tool body.

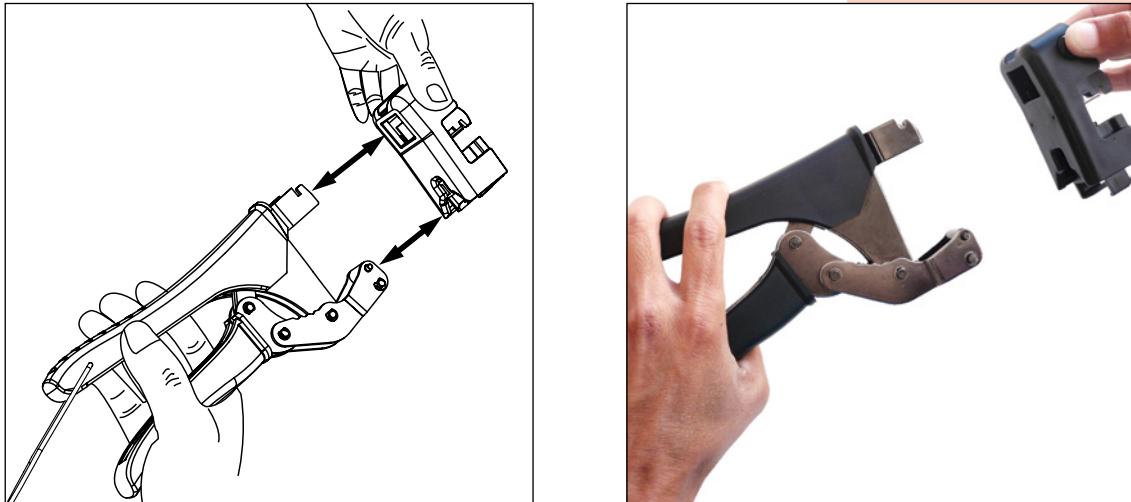

2.- Press the button at both sides while pushing the body on to the head with the Die until securely fixed.

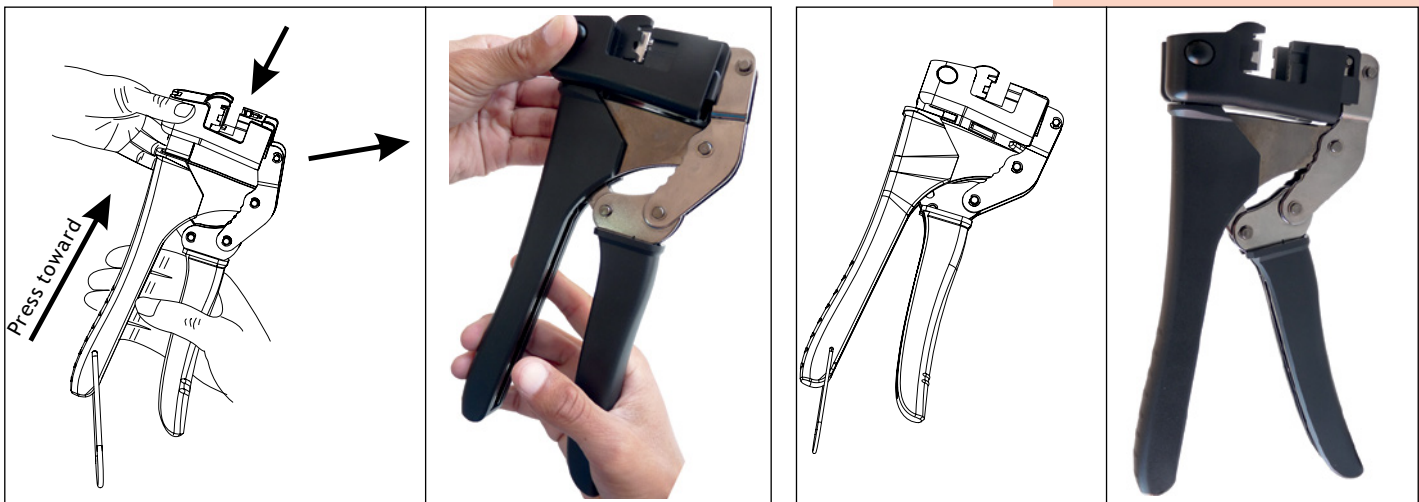

3.- Move forward the die and make sure it is completely fixed.

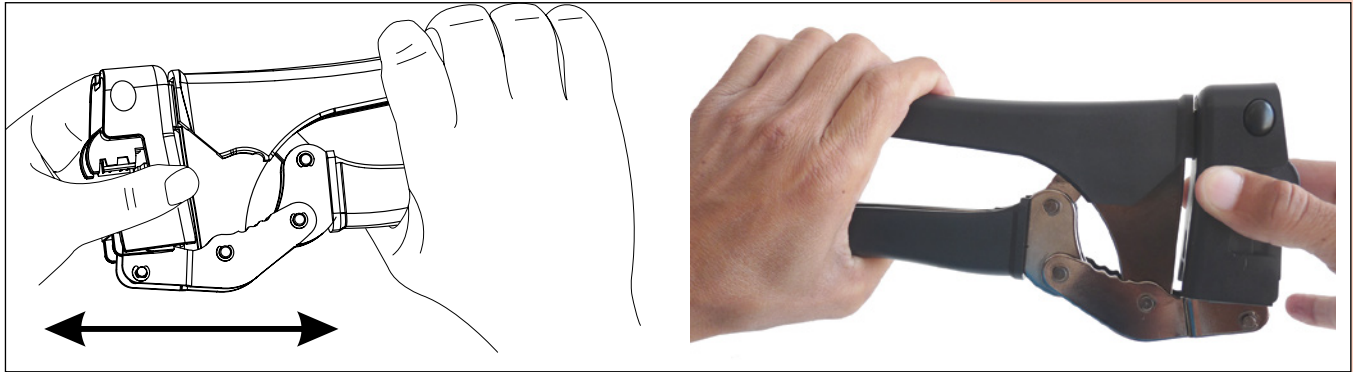

C Precautions

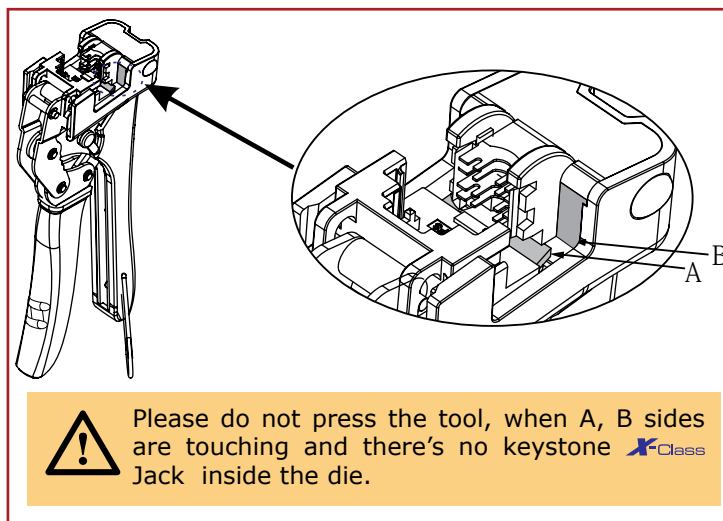
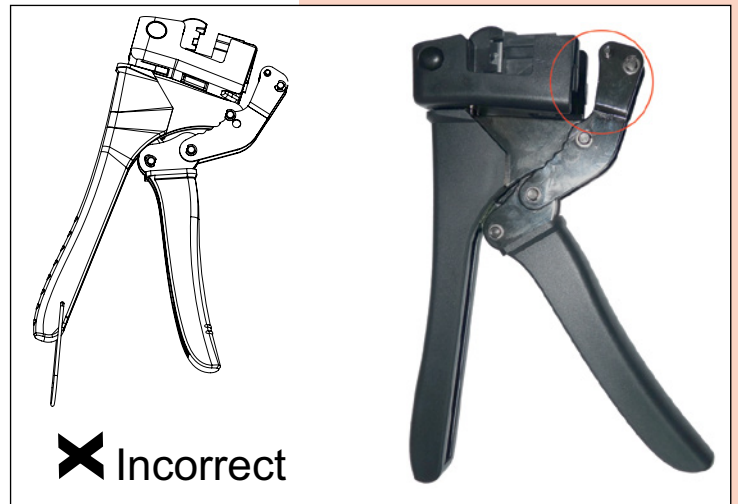
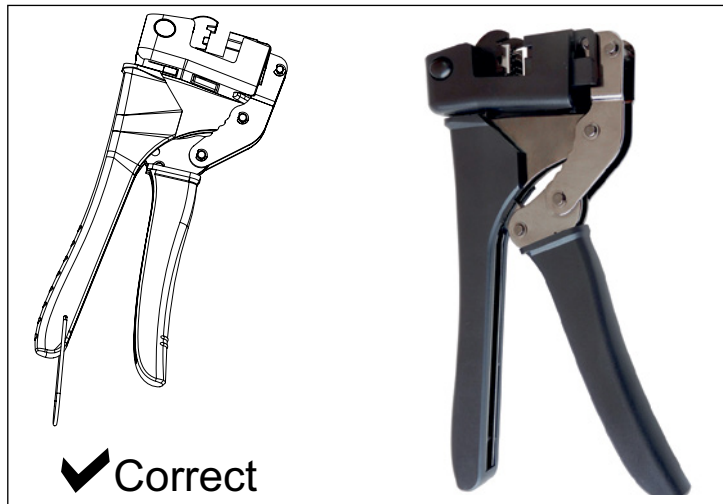

D Termination

Install the wires and place them securely into the insulation displacement terminals, following the appropriate color code (T568A or T568B).

