

**LP-OSFPZX01 SFP Optical Transceiver module, LC Duplex,
1.25 Gbps 1000BASE-ZX, 1550 nm, Single MODE (9/125 μm), up to 80 Km
or Multimode 50/125 μm /62.5/125 μm up to 550 m**

LPOSFPZX01_SS_ENB01W

Features

- SFP package with LC connector.
- 1550 nm DFB laser and PIN photo detector.
- 550 m transmission with MMF.
- 80 Km transmission with SMF.
- +3.3V single power supply.
- LVPECL compatible data input/output interface.
- Low EMI and excellent ESD protection.
- Laser safety standard IEC-60825 compliant.
- Compatible with RoHS.
- Hot-pluggable SFP footprint.

Applications

- Ethernet
- Telecom



**LP-OSFPZX01
SFP Optical Transceiver module, LC Duplex,
1.25 Gbps 1000 BASE-ZX, 1550 nm, Single MODE
(9/125 μm), up to 80 Km or Multimode
50/125 μm /62.5/125 μm up to 550 m**

The SFP transceiver supports dual data-rate of 1.25 Gbps/1.0625 Gbps and from 80 km transmission distance with SMF or 550m with MMF.

The transceiver consists of two sections: The transmitter section incorporates a 1550 nm DFB laser. The receiver section consists of a PIN photodiode integrated with a trans-impedance preamplifier (TIA).

All modules satisfy class I laser safety requirements. The optical output can be disabled by a TTL logic high-level input of Tx Disable. Tx Fault indicates that degradation of the laser. Loss of signal (LOS) output indicates the loss of an input optical signal of receiver.

The standard serial ID information compatible with SFP MSA describes the transceiver's capabilities, standard interfaces, manufacturer and other information. The host equipment can access this information via the 2-wire serial bus. For more information, please refer to SFP Multi-Source Agreement (MSA).

A Performance specifications:

Absolute Maximum Ratings

Parameter	Symbol	Minimum	Maximum	Units
Storage Temperature	Tst	-40	+85	°C
Operating Temperature	Top	0	+70	°C
Supply Voltage	Vcc	0	+3.6	V
Input voltage	Vin	GND	Vcc	-
Lead Soldering Temperature & Time	-	240/10	-	°C/s

B Operation Environment:

Parameter	Symbol	Minimum	Maximum	Units
Supply Voltage	Vcc	3.15	3.45	V
Ambient operating Temperature	Top	0	+70	°C
Operating Relative Humidity	-	5	95	%

C Transmitter Section:

(Ambient Operating Temperature 0°C to +70°C, Vcc =3.3 V)

Parameter	Symbol	Min.	Typ.	Max.	Units
Data rate	-	-	1250	-	Mb/s
Center Wavelength	λ_0	1270	1310	1350	nm
Output Spectral width	$\Delta\lambda$	-	-	4	nm
Average Optical Output Power	Po	0	-	5	dBm
Extinction Ratio	Er	10	-	-	dB
Rise/Fall Time(20%~80%)	Tr/Tf	-	-	0.26	ns
Total jitter	Tj	-	-	0.43	UI
Optical Eye Diagram	IEEE 802.3z and ANSI Fibre Channel Compatible				
Input differential impedance	Zdiff	-	100	-	Ohm
TX disable	Disable	2.0	-	Vcc	V
	Enable	0	-	0.8	V
Fault	Fault	2.0	-	Vcc+0.8	V
	Normal	0	-	0.8	V

D Receiver Section:

(Ambient Operating Temperature 0°C to +70°C, Vcc =3.3 V)

Parameter	Symbol	Min.	Typ.	Max.	Unit
Data rate			1250		Mb/s
Wavelength	λ	1270	1310	1570	nm
Maximum Input Power	P _{max}	0	-	-	dBm
Receiver Sensitivity	P _{min}	-	-27	-25	dBm
Output differential impedance	Zdiff	-	100	-	Ohm
LOSS Thresholds	LOSS _D	-	-	-31	dBm
	LOSS _A	-34	-	-	-

E EEPROM Information:

Addr	Field Size (Bytes)	Name of Field	HEX	Description
0	1	Identifier	03	SFP
1	1	Ext. Identifier	04	MOD4
2	1	Connector	07	LC
3-10	8	Transceiver	00 00 00 02 12 00 0D 01	Transmitter Code
11	1	Encoding	01	8B10B
12	1	BR, nominal	0D	1250M bps
13	1	Reserved	00	-
14	1	Length (9um)-km	0A/14/28/50	10 km/20 km/40 km/80 km
15	1	Length (9um)	64/C8/FF	-
16	1	Length (50um)	37	550 m
17	1	Length (62.5um)	37	550 m
18	1	Length (copper)	00	-
19	1	Reserved	00	-
20-35	16	Vendor name	57 49 4E 54 4F 50 20 20 20 20 20 20 20 20 20 20	Marstars
36	1	Reserved	00	-
37-39	3	Vendor OUI	00 00 00	-
40-55	16	Vendor PN	xx xx xx xx xx xx xx xx xx xx xx xx xx xx xx xx	ASC II
56-59	4	Vendor rev	31 2E 30 20	V1.0
60-61	2	Wavelength	05 1E	1310 nm
62	1	Reserved	00	-
63	1	CC BASE	XX	Check sum of byte 0~62
64-65	2	Options	00 1A	LOS, TX_DISABLE, TX_FAULT
66	1	BR, max	32	50%
67	1	BR, min	32	50%
68-83	16	Vendor SN	00 00 00 00 00 00 00 00 00 00 00 00 00 00 00 00	Unspecified
84-91	8	Vendor date code	XX XX XX 20	Year, Month, Day
92-94	3	Reserved	00	-
95	1	CC_EXT	XX	Check sum of byte 64~94
96-255	160	Vendor specific	-	-

F Pin Description:

Pins	Name	Discription	NOTE
1	VeeT	Transmitter Ground	
2	Tx Fault	Transmitter Fault Indication	1
3	Tx Disable	Transmitter Disable	2
4	MOD DEF2	Module Definition 2	3
5	MOD DEF1	Module Definition 1	3
6	MOD DEF0	Module Definition 0	3
7	Rate Select	Not Connected	-
8	LOS	Loss of Signal	4

F Pin Description:

9	VeeR	Receiver Ground	-
10	VeeR	Receiver Ground	-
11	VeeR	Receiver Ground	-
12	RD-	Inv. Received Data Output	5
13	RD+	IReceived Data Output	5
14	VeeR	Receiver Ground	-
15	VccR	Receiver Power	-
16	VccT	Transmitter Power	-
17	VeeT	Transmitter Ground	-
18	TD+	Transmit Data Input	6
19	TD-	Inv. Transmit Data Input	6
20	VeeT	Transmitter Ground	-

Notes:

- TX Fault is an open collector output, which should be pulled up with a 4.7k ~ 10kΩ resistor on the host board to a voltage between 2.0 V and Vcc+0.3 V. Logic 0 indicates normal operation; logic 1 indicates a laser fault of some kind. In the low state, the output will be pulled to less than 0.8 V.
- TX Disable is an input that is used to shut down the transmitter optical output. It is pulled up within the module with a 4.7k ~ 10kΩ resistor. Its states are:
Low (0 ~ 0.8V): Transmitter on
(>0.8V, <2.0V): Undefined
High (2.0 ~ 3.465V): Transmitter Disabled
Open: Transmitter Disabled
- MOD-DEF 0,1,2 are the module definition pins. They should be pulled up with a 4.7k ~ 10kΩ resistor on the host board. The pull-up voltage shall be VccT or VccR.
MOD-DEF 0 is grounded by the module to indicate that the module is present
MOD-DEF 1 is the clock line of two wire serial interface for serial ID
MOD-DEF 2 is the data line of two wire serial interface for serial ID
- LOS is an open collector output, which should be pulled up with a 4.7k ~ 10kΩ resistor on the host board to a voltage between 2.0 V and Vcc+0.3 V. Logic 0 indicates normal operation; logic 1 indicates loss of signal. In the low state, the output will be pulled to less than 0.8 V.
- These are the differential receiver output. They are internally AC-coupled 100Ω differential lines which should be terminated with 100Ω (differential) at the user SERDES.
- These are the differential transmitter inputs. They are AC-coupled, differential lines with 100Ω differential termination inside the module.

G Recommended Application Circuit:

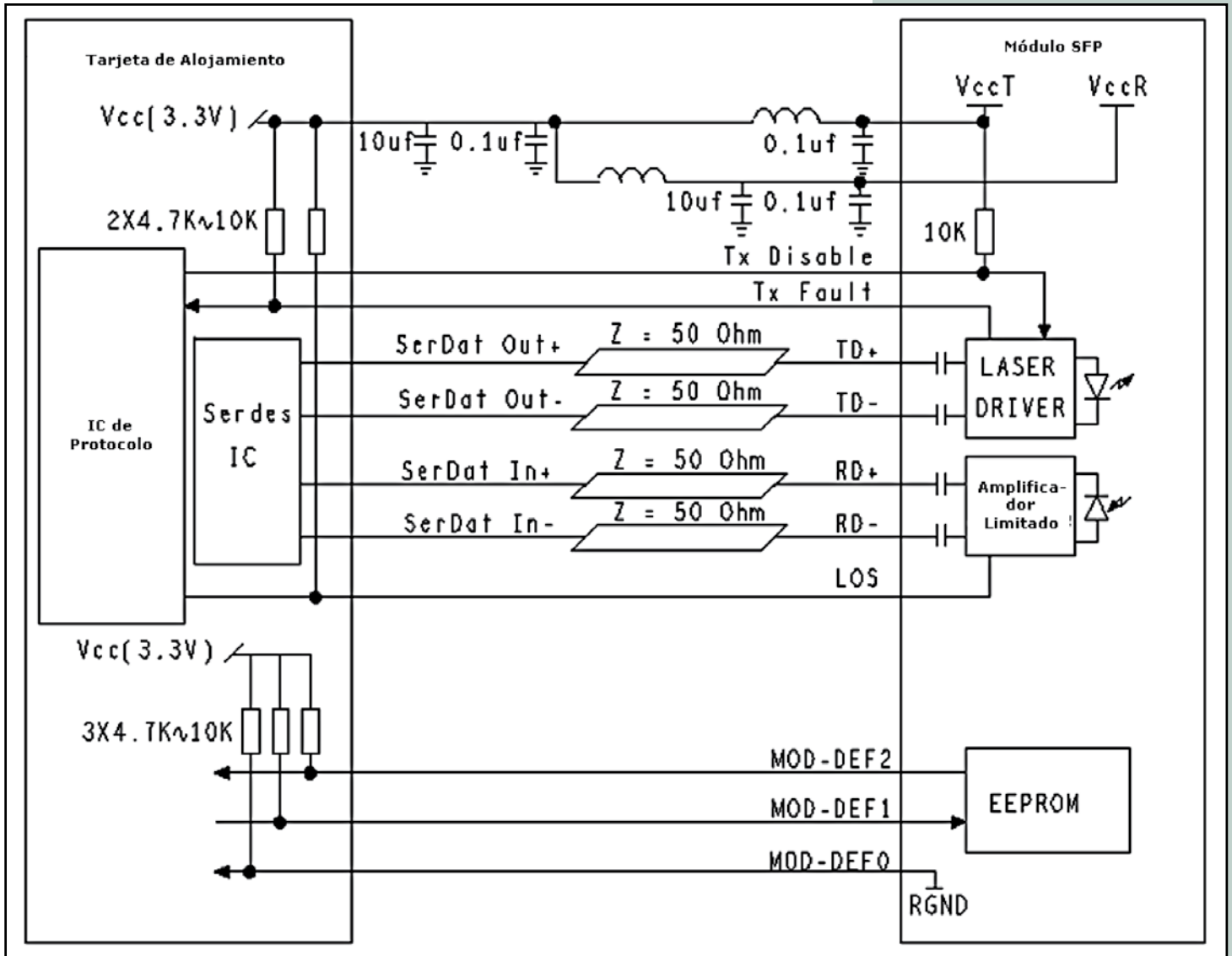

H How to Order:

LP-OSFPZX01 SFP Optical Transceiver module, LC Duplex, 1.25 Gbps 1000 BASE-ZX, 1550 nm, Single MODE (9/125 μm), up to 80 Km or Multimode 50/125 μm/62.5/125 μm up to 550 m.