

LP-OSFPLX03 LC duplex 1000BASE-LX 1.25Gb/s 9/125 μm Singlemode Fiber SFP 1310nm MSA Transceiver up to 20 Km.

LPOSFPLX03_SS_ENB01W

Features

- Up to 1.25Gb/s bi-directional data links.
- Hot-pluggable SFP footprint.
- 1310nm Fabry-Perot laser transmitter.
- Duplex LC connector.
- Very low jitter.
- No rate Select input required for Fiber channel 1x Operation.
- Up to 20 Km on 9/125μm SMF.
- Metal enclosure, for lower EMI.
- Single 3.3V power supply.
- Low power dissipation <700mW typical.

Applications

- Gigabit Ethernet.
- 1x Fiber Channel.
- Switch to Switch interface.
- Switched backplane applications.
- Router/Server interface.
- Other optical transmission systems.



**LP-OSFPLX03
LC duplex 1000BASE-LX
1.25Gb/s 9/125 μm Singlemode Fiber SFP
1310nm MSA Transceiver up to 20 Km.**

The LP-OSFPLX03 Small Form Factor Pluggable (SFP) transceivers are compatible with the Small Form Factor Pluggable Multi-Sourcing Agreement (MSA). They simultaneously comply with Gigabit Ethernet as specified in IEEE Std 802.31 and 1x Fiber Channel as defined in FC-PI 13.03.

A Pin Assignment

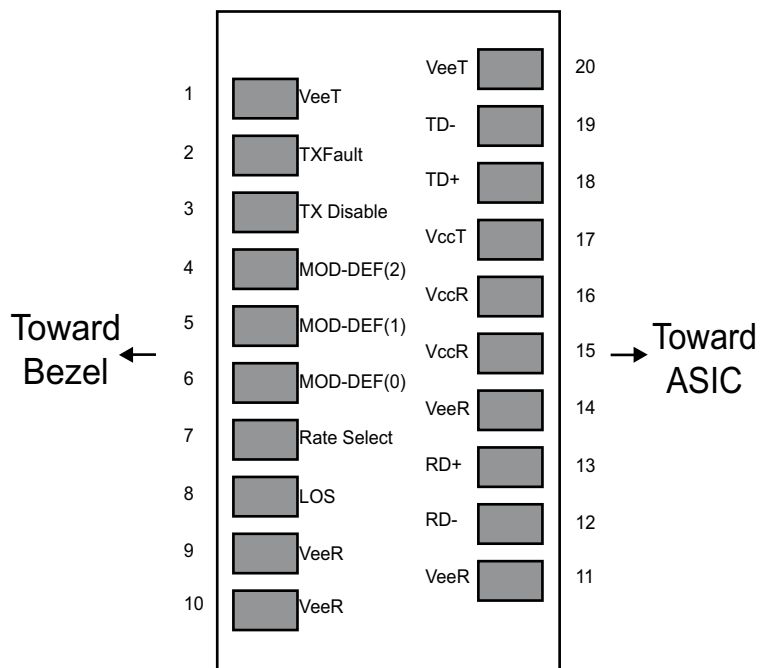

B Pin Descriptions

Pin	Signal Name	I/O Typ.	Functional Description
1	VeeT		Transmitter Ground.
2	TX_FAULT		Transmitter Fault Indication, Logic high, open collector Compatible , 4.7K to 10K Ohm pull up to VDDT on host.
3	TX_DISABLE		Transmitter Disable – Module disable on high or open (Not Used).
4	MOD_DEF(2)	I/O	Module Definition 2 Two wire serial ID interface SDA, 4.7 K to 10K Ohm pull up to VDDT on host.
5	MOD_DEF(1)	Input	Module Definition 1 Two wire serial ID interface SCL, 4.7 K to 10K Ohm pull up to VDDT on host.
6	MOD_DEF(0)	Output	Module Definition 0 TTL Low.
7	Rate Select	Input	Select between full or reduced receiver bandwidth The undefined.
8	LOS		Receiver Loss of Signal, Logic high, Open collector compatible 4.7 K to 10 K Ohm pull up to VDDT on host.
9	VeeR		Receiver Ground
10	VeeR		Receiver Ground
11	VeeR		Receiver Ground
12	RD-	Output	Inverse Received Data Out, Differential PECL, at AC couple
13	RD+	Output	Received Data Out, Differential PECL, at AC couple
14	VeeR		Receiver Ground
15	VccR	Input	Receiver Power
16	VccT	Input	Transmitter Power
17	VeeT		Receiver Ground
18	TD+	Input	Transmitter Data In, Differential PECL, AC couple
19	TD-	Input	Inverse Transmitter Data In, Differential PECL, AC couple
20	VeeT		Transmitter Ground

Notes:

1	Circuit ground is internally isolated from chassis ground.
2	Laser output disabled on TDIS >2.0 V or open, enabled on TDIS <0.8 V.
3	Should be pulled up with 4.7 k - 10 K Ohm on host board to a voltage between 2.0 V and 3.6 V. MOD_DEF (0) pulls line low to indicate module is plugged in.
4	LP-OSFPLX03 transceivers operate at 1x Fiber Channel and Gigabit Ethernet data rates and respective protocols without active control.
5	LOS is open collector output. Should be pulled up with 4.7 k – 10 K Ohm on host board to a voltage between 2.0 V and 3.6 V. Logic 0 indicates normal operation; logic 1 indicates loss of signal.

D Absolute Maximum Ratings

Parameter	Symbol	Min	Typ	Max	Unit	Ref.
Maximum Supply Voltage	Vcc	-0.5		4.5	V	
Storage Temperature	TS	-40		100	°C	
Case Operating Temperature	TOP	-40		85	°C	
Relative Humidity	RH	0		85	%	1

E Electrical Characteristics (TOP = -40 to 85_ , VCC = 3.00 to 3.60 Volts)

Parameter	Symbol	Min	Typ	Max	Unit	Ref.
Supply Voltage	Vcc	3.00		3.60	V	
Supply Current	Icc	200		300	mA	
Transmitter						
Input differential impedance	Rin		100		Ω	2
Single ended data input swing	Vin,pp	250		1200	mV	
Transmit Disable Voltage	VD	Vcc-1.3		Vcc	V	
Transmit Enable Voltage	VEN	Vee		Vee+0.8	V	3
Transmit Disable Assert Time			10		us	
Receiver						
Single ended data output swing	Vout,pp	300	400	800	mV	4
Data output rise time	tr		100	175	ps	5
Data output fall time	tf		100	175	ps	5
LOS Fault	VLOS fault	Vcc -0.5		VccHOST	V	6
LOS Normal	VLOS norm	Vee		Vee+0.5	V	6
Power Supply Rejection	PSR	100			mVpp	7
Deterministic Jitter Contribution	RX Δ DJ			51.7	ps	8
Total Jitter Contribution	RX Δ TJ			122.4	ps	

Notes:

1	Non condensing.
2	AC coupled.
3	Or open circuit.
4	Into 100 ohm differential termination.
5	20 – 80 % Page 4 of 8
6	LOS is LVTTTL. Logic 0 indicates normal operation; logic 1 indicates no signal detected.
7	All transceiver specifications are compliant with a power supply sinusoidal modulation of 20 Hz to 1.5 MHz up to specified value applied through the power supply filtering network shown on page 23 of the Small Form-factor Pluggable (SFP) Transceiver Multi-Source Agreement (MSA), September 14, 2000.
8	Measured with DJ-free data input signal. In actual application, output DJ will be the sum of input DJ and Δ DJ.

F Optical Characteristics (TOP = 0 to 70_ , VCC = 3.00 to 3.60 Volts)

Parameter	Symbol	Min	Typ	Max	Unit	Ref.
Transmitter						
Output Opt. Power	POUT	-9		-3	dBm	1
Optical Wavelength	λ	1270	1310	1360	nm	2
Spectral Width	σ			4	nm	2
Optical Modulation Amplitude	OMA	174			μ W	2,3
Optical Rise/Fall Time	tr/ tf		100	160	ps	4
RIN				-120	dB/Hz	
Deterministic Jitter Contribution	TX Δ DJ		20	56.5	ps	5
Total Jitter Contribution	TX Δ TJ		70	119	ps	
Optical Extinction Ratio	ER	8.2			dB	
Receiver						
Average Rx Sens@1.25 Gb/s (Gigabit Ethernet)	RSENS2			-22	dBm	6, 7
Average Rx Sens @1.06 Gb/s (1X Fiber Channel)	RSENS1			-23	dBm	6, 7
Average Received Power	RxMAX			0	dBm	

K Recommended Front Panel Layout Opening for LC

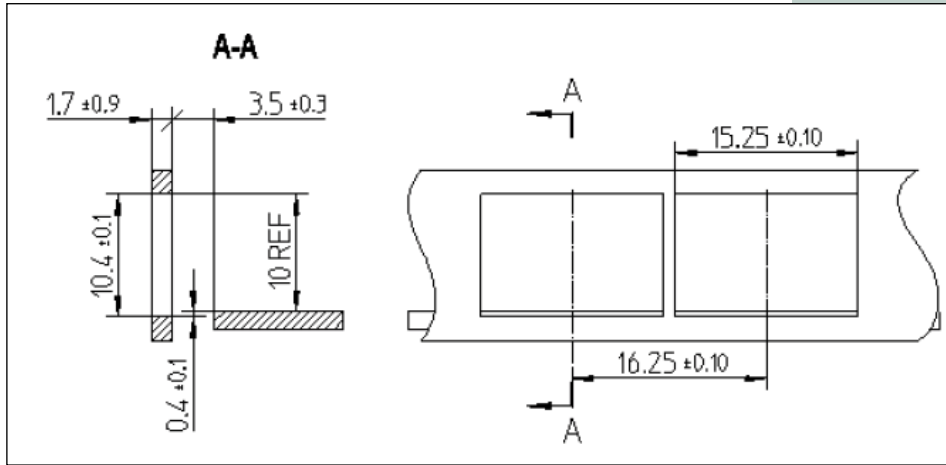

L Recommended application circuit

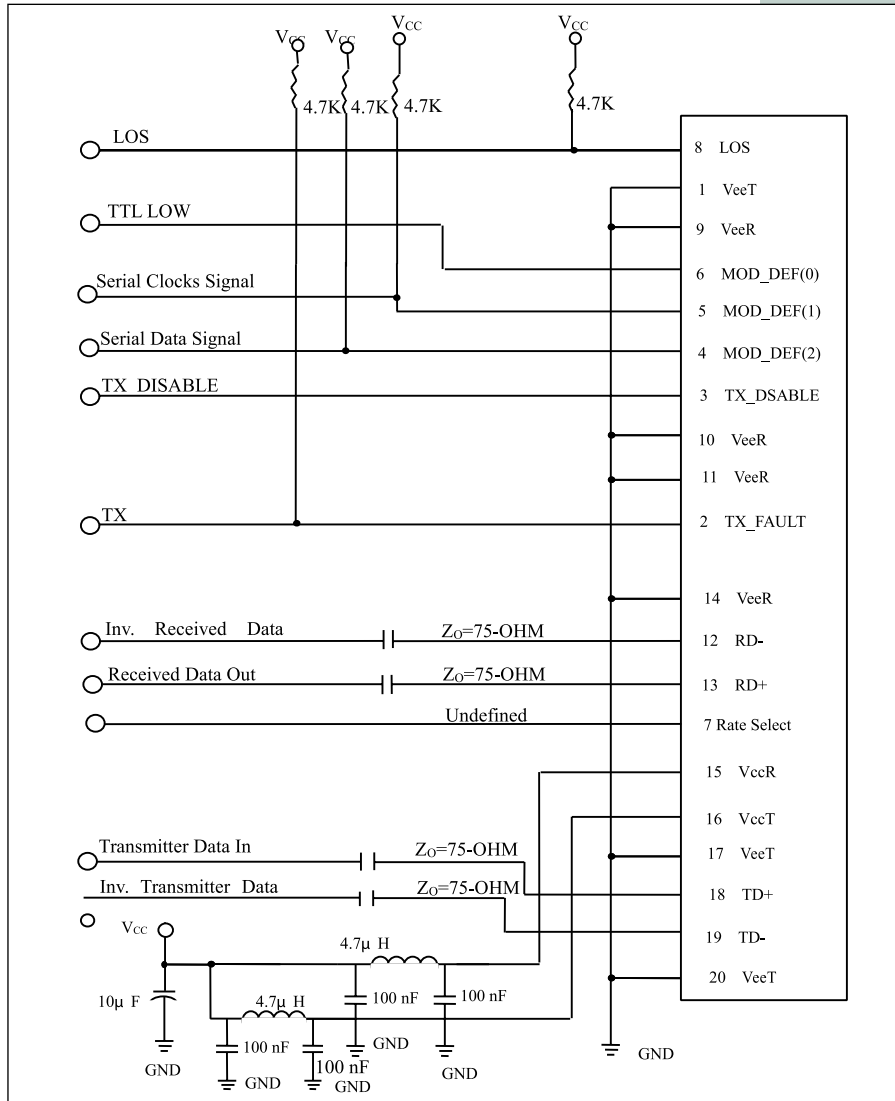

M How to Order

LP-OSFPLX03

LC duplex 1000BASE-LX1.25Gb/s 9/125 µm Singlemode Fiber SFP 1310nm MSA Transceiver up to 20 Km.